

# CSE 260M - Homework 4

*Due September 27, 2006*

1. For the Boolean functions E and F, as given in the following truth table:

X	Y	Z	E	F
0	0	0	1	0
0	0	1	1	0
0	1	0	1	1
0	1	1	0	1
1	0	0	0	0
1	0	1	1	0
1	1	0	0	1
1	1	1	0	1

- List the minterms and and maxterms of each function. Show both the algebraic and shorthand versions.
  - List the minterms of  $E'$  and  $F'$ . Show both the algebraic and shorthand versions.
  - List the minterms of  $E+F$  and  $EF$ . Show both the algebraic and shorthand versions.
  - Express E and F in sum-of-minterms algebraic form.
  - Simplify E and F to expressions in SOP form. (Using a K-map is fine).
2. Simplify each of the following Boolean Functions into a SOP and POS form using a 3-variable Karnaugh Map:
- $F(X,Y,Z) = \Sigma m(1,3,6,7)$
  - $F(X,Y,Z) = \Sigma_{X,Y,Z} (0,1,4,5,7)$
  - $F(X,Y,Z) = \Sigma_{X,Y,Z} (0,2,3,4,6)$
  - $F(X,Y,Z) = \Pi_{X,Y,Z} (3,5,7)$

3. Simplify each of the following Boolean functions into SOP and POS forms using a 4-variable Karnaugh Map:
- $F(W,X,Y,Z) = \Sigma_{W,X,Y,Z}(0,1,2,6,8,9,10,13)$
  - $F(W,X,Y,Z) = \Sigma_{W,X,Y,Z}(2,3,5,7,8,10,12,13)$
  - $F(W,X,Y,Z) = \Pi_{W,X,Y,Z}(1,3,5,6,7,10,14)$
  - $F(W,X,Y,Z) = \Pi_{W,X,Y,Z}(2,10,13)$
4. Minimize the following functions into a minimal SOP form:
- $F(W,X,Y,Z) = \Sigma_{W,X,Y,Z}(1,7,10,13,15) + d(3,6,9,14)$
  - $F(W,X,Y,Z) = \Sigma(0,8,10,12,13,14,15) + d(1,4,5,11)$
5. You work for the mega-design company Letni. Due to the recent economic downturn, all circuit designs are being reevaluated to reduce costs. You are given the task of reducing cost in the following circuit. Assuming that all gates cost \$0.10 per input (an inverter is \$0.10, a 2-input gate is \$0.20, etc.) find the minimum cost circuit for the following using only inverters, AND/OR gates.

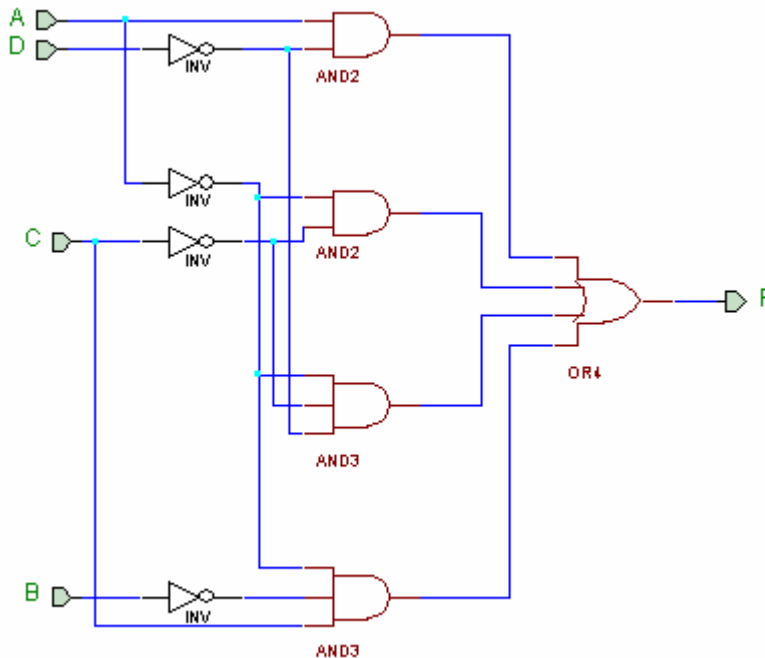

6. The following K-map is for a function that is true when the input is a prime BCD digit. Minimize this function assuming all the don't cares (d) are 0 and then repeat for them all being a 1. Finally, minimize this function using the don't cares "properly" and then comment on which yields the best result and why.

	$N_1N_0$	$N_3N_2$	00	01	11	10
00					d	
01			1	1	d	
11			1	1	d	d
10			1		d	d